

# Introducing electricity load level detail into a CGE model – The GEMED model

Renato Rodrigues<sup>1</sup>, Pedro Linares<sup>2</sup>

July 9, 2012

## Abstract

The growing importance of the electricity sector in many economies, and of energy and environmental policies, requires a detailed consideration of these sectors and policies in computable general equilibrium (CGE) models, including both technological and temporal aspects. This paper presents the first attempt to our knowledge at building temporal disaggregation into a CGE model, while keeping technological detail. This contribution is coupled with some methodological improvements over existing technology-rich CGE models. The results of the case study clearly show the enhanced capability of this model for assessing complex policies with load shifting, demand profile changes and technology substitution. The model is able to account for the indirect effects characteristic of CGE models while also mimicking the detailed behavior of the electricity operation and investment present before only in bottom-up detailed models.

*Keywords: Computable General Equilibrium (CGE), Electricity Demand Response.*

*JEL Codes: C68, D58, Q4, Q51, L60.*

## 1 Introduction

The last years have seen a huge effort in improving the representation of the energy sector in computable general equilibrium (CGE) models. The major motivation for this effort lies in the limitations of CGE when dealing with energy and environmental policies, in which the energy sector may play a relevant role:

---

<sup>1</sup> Corresponding author, email: renato.rodrigues@iit.upcomillas.es, tel.: +34 91 542-2800 Ext. 2755, fax: +34 91 542-3176. Instituto de Investigación Tecnológica, Comillas P. University, C/ Santa Cruz de Marcenado 26, 28015, Madrid, Spain.

<sup>2</sup> Instituto de Investigación Tecnológica, Comillas P. University; Economics for Energy; and Harvard Kennedy School.

these policies may change the way technologies or fuels are used, and these changes may have broader economic consequences which need to be accounted for.

However, the detail of representation of the electricity sector has not been very large, and has been focused mostly on introducing technological detail (McFarland & Reilly, 2004, Paltsev et al., 2005 and Sue Wing, 2008) or feeding the CGE model with a BU-determined electricity behavior (Böhringer & Rutherford, 2008). This may be explained in part by the rabbit-and-elephant analogy introduced by Hogan and Manne (1977) and reminded by Ghersi and Hourcade (2006): the role of the energy sector in the economy is small, and even smaller the one of the electricity part of it. However, this analogy will probably not remain valid for a long time, at least for the contribution of electricity to the energy sector: we are already experiencing an increased electrification of the energy sector, and this will only grow in the medium term with the introduction of electric vehicles. Then, probably the rabbit will become an elephant, and the shortcomings of CGE models regarding the representation of the electricity sector will become more acute.

Indeed, the case of electric vehicles is a nice example of why there may be more reasons to introduce more detail in the representation of electricity supply and demand: the largest effect of these vehicles will not be in the amount of electricity produced, but rather, in the moment in which it is produced and consumed. The same happens with the expected impact of the demand-response programs currently being promoted associated with the smart meter rollout in many countries. And this change in the time in which electricity is produced or consumed is more relevant than it seems. Because of the non-storability of electricity, we might argue that electricity is not a single good: instead, it may be considered a different good depending on the time of the day it is produced or consumed. And, as such, it has different prices in different time periods. These differences in prices may be very relevant: in liberalized electricity markets (such as most of the European ones, but also in the US or other countries), the prices paid for electricity are not averages, but marginal ones. The change in the moment when electricity is used will change these marginal prices, and these are the prices that will be sent to the rest of the economy, not the average ones (which may not change) used by the typical CGE model. Introducing technological detail does not solve this problem.

Therefore, if we want to accurately represent the impact of energy or environmental policies on electricity prices, and of these prices in the rest of the economy, we need to consider an additional level of detail: time period detail, or, in power systems jargon, load level detail. This is even more important for policies that modify the moment of time in which electricity is consumed.

The objective of this paper is hence to present a CGE model in which both technology and load level detail are introduced for the electricity sector, and to apply it to the evaluation of the abovementioned policies, in this case a demand-response program in Spain. Our results show that this improved detail in the electricity sector does change the estimation of the overall effects of the policy. Moreover, and unlike previous exercises, we show that the approach is feasible even for country-level systems, such as the Spanish one.

The paper is structured as follows. Sections two and three describe the methodology and the model used for introducing technology and load level detail into the CGE model. Section four presents results of the assessment and compares them to previous approaches. Finally, we offer some conclusions and thoughts about further research on this area.

## **2 Conceptual framework**

CGE models represent economic activities as yearly aggregated commodities, which are produced at the efficient frontier of specific production functions by the combination of diverse production factors and supplementary commodities. The functional parameters that determine these production functions (elasticities and technological parameters) are estimated from real world behavior.

The commodity “electricity” at a specific point in time is a homogeneous product. However, its production portfolio is composed by several and very dissimilar production techniques. Therefore a single production function, such as the ones used in seminal CGE modeling like Hertel & Horridge (1997), Robinson et al. (1999) and Löfgren et al. (2002) are not enough to represent correctly the electricity sector.

Accordingly, several researchers have sought to achieve a higher degree of technological disaggregation or fuel supplier sectors representation in the

electricity sector under the CGE modeling approach. Most of the largely adopted E3 assessment models like OECD-Green (J. Burniaux & Nicoletti, 1992), GTAP-E (J.-M. Burniaux & Truong, 2002) and MIT-EPPA (McFarland & Reilly, 2004 and Paltsev et al., 2005) underwent an continuous update process to better reflect the energy sectors dynamics. Nested energy production functions began to be used to reflect different fuel usage or different production technologies in the electricity sector.

However, such CGE extensions disregarded a crucial feature of electricity markets: their time dimension. Even if electricity is a homogeneous product at a specific moment in time, it becomes a heterogeneous commodity when considering different moments in time. This results from the fact that the electricity produced at a certain moment in time cannot be consumed at another period due to the impracticability<sup>3</sup> of storing it. As a consequence, technological disaggregation alone is not capable of representing correctly the electricity sector behavior. Most of the recent policy evaluations related with the electricity production and consumption behavior also disregard the time heterogeneity of electricity in their CGE formulation. Some recent examples are: Löschel & Otto (2009) that study the role of carbon capture and storage (CCS) uncertainty in emission reduction policies; Fæhn et al. (2009) that evaluate the consequences of carbon permit systems to unemployment in Spain; Turner & Hanley (2011) that investigate the environmental Kuznets curve under technological change; Bye & Jacobsen (2011) that look at welfare consequences of R&D and carbon taxes iterations; or Beckman et al. (2011) about the validation of GTAP-E parameters against historical numbers. Rausch et al. (2011) represented an important advance in the representation of meaningful features in the evaluation of carbon pricing distributional effects in the U.S., like regional and income groups disaggregation, but time disaggregation was not taken into account in the CGE definition.

Some CGE models tried to overcome this limitation by taking into account in their technology disaggregation different technology portfolios characterized by their capacity factor and time of use. McFarland and Herzog (2006) is one example that makes use of this information to divide baseload technologies (typically coal and

---

<sup>3</sup> Currently available technologies (batteries, heat and inertial storage, pumping, water management, etc.) present prohibitive costs for storage.

nuclear power plants), intermediate load capacity (natural gas combined cycle plants) and peaking capacity (simple cycle gas turbines) in order to assess the incorporation of carbon capture and storage in an integrated assessment.

However, including different time-dependable electricity technologies under the same nested production function, i.e., making use of different production functions for the same technologies under peak and off-peak demand periods, despite enriching the technology description, does not represent a real implementation of the heterogeneity in time of the electricity commodity.

Representing electricity production within a single nested structure implies the existence of a single electricity commodity, which presents average costs, prices and quantities. However, the information contained in average prices is not able to truthfully reflect the actual behavior of electricity prices in competitive, marginal-price electricity markets. In these markets, the electricity generation price corresponds to the bid of the marginal unit - the last power plant required to be dispatched at each time period -, and has no direct relation with average prices.

Therefore, there is no guarantee that an increase in the electricity demand would present an additional cost in the neighborhood of the average cost reflected in the national accounts. Actually, even the direction of the effect in prices is uncertain without further information. For example, an increase in the electricity demand in hours of lower demand (off-peak periods) would present a cost lower than the average price of electricity, since the additional energy needed to be produced could make use of cheaper variable cost power plants. As a consequence, the increase in demand would actually decrease the average price of electricity. Meanwhile, the opposite effect would occur if the increase in demand happens in peak hours, because costs incurred by the need of using more expensive variable cost units of production to serve the new demand would be greater than the initial average electricity price.

It is then evident that in any policy evaluation where electricity demand shifts or reductions are considered it is important to regard electricity as a heterogeneous commodity. This can only be done if we consider different electricity products for different time periods.

The difficulty to represent such detail inside a pure CGE model has led many researchers to adopt a partial top-down (TD) solution by making use of auxiliary bottom-up (BU) electricity models. Under this approach, the CGE model is fed exogenously by a bottom-up model that simulates the behavior of the electricity sector (Rutherford & Montgomery (1997) and Lanz & Rausch (2011)).

The use of a BU model to simulate electricity production adds flexibility to the representation of the specificities of electricity production technologies. However, the lack of electricity detail in the TD CGE model limits the information shared between these models to average values. Load block prices and quantities disparities, and their consequences for the general equilibrium income effects, consumer decisions, commodities substitutions and production costs are overlooked by such models and could limit their capability of evaluating economy-wide market interactions derived from energy policies.

This paper aims to present an answer to this problem. As we will see, it is possible to develop a pure CGE formulation suited to such complex policy assessments by incorporating at the same time the technological and the load level detail at the electricity demand and production levels.

Some key points must be addressed by such a model. Firstly, the resulting CGE model must present as many differentiated electricity commodities as the number of different technological portfolios used to provide electricity at the different demand levels. Secondly, the technology portfolio used at each load block must maintain the correspondence with the physical production characteristics of each production technology (thermodynamic efficiency, fuel use, self-consumption, availability, maintenance costs, specific subsidies, etc.). Thirdly, all costs that are not load-block-specific must maintain compatibility with their respective load block use of each technology (amortization of fixed costs, non-variable costs, start-up and ramp costs, market imperfection rents, etc.). Moreover, all the income created by the demand profiles of the different economic agents must be exactly equal to the production costs and the market power rents pertaining to each load block. The last requirement is necessary in order to maintain the model compatibility with the market clearing and zero profit conditions embedded in the Social Accountability Matrix (SAM) scheme.

As can be inferred from the points highlighted above, the introduction of technology and load level detail into CGE models faces several of the obstacles faced by the more comprehensive problem of convergence between BU and TD approaches.

Some papers already proposed a calibration procedure for making compatible both models in terms of data under a technology-only disaggregation scheme. Ian Sue Wing (2008) implemented a calibration procedure which consisted in disaggregating the SAM economic data into different electricity producing technologies by approximating the production factors and intermediate input expenditures according to expenditure shares obtained from real technological data, such as thermodynamic efficiency, labor use and construction capital requirements. Under this alternative the calibration problem is defined as the minimization of the deviations between the calibrated share of expenditures in intermediate inputs and production factors vs. the shares calculated from the benchmark bottom-up information.

The use of expenditure shares in calibrating the SAM aggregate presents some problems. The first and more essential one is the loss of the linkage between the original technological parameters, which determine the initial shares, and the resulting aggregate expenditures. Under this approach it is very difficult to incorporate changes in the original technological parameters without making additional exogenous assumptions or calibrating the SAM again. Therefore, this calibration solution is more appropriate to evaluate policies where technological changes are not critical.

Another limitation to the shares approach is the case when the determination of the expenditure shares does not take into account exhaustively the real market costs. In this case, an inconsistency between the national accounts and the original technological data would be evenly distributed between all costs sources. This feature helps achieve faster calibrated results; however it can also mask the presence of non-accounted costs or the existence of meaningful differences in the accounting data schemes of BU and TD data not taken into account during the calibration procedure.

The direct calibration of the technological parameters, instead of the use of shares, can overcome both limitations cited above. Under this alternative the calibration

problem is defined as the direct minimization of the deviations between the calibrated technological parameters and the original data. Additional equations are used to derive arithmetically the social accountability aggregates departing from the calibrated microeconomic information. If technological changes matter, as for the case e.g. of substantial learning by doing effects, we can directly change the technological parameters in order to achieve the new macroeconomic figures. If an important cost source is overlooked in the problem definition the macroeconomic totals will present a very dissimilar result or the technological parameter will present a large deviation level, thus identifying the problem. The trade-off of using this approach lies in the fact that convergence is more difficult to achieve because of the need to calibrate a larger number of variables (one calibrated variable for each technological parameter considered) and additional equations needed to obtain the macroeconomic (micro-founded) totals and to enforce the SAM accountability equilibrium.

The choice of the mathematical formulation also influences the results obtained. Most of the literature related with this kind of calibrations, including Wing's work, makes use of quadratic objective functions for minimizing the errors between the original and the calibrated values. Although these functions allow for fast convergence, they can also result in a concentration of deviations in critical parameters (such as thermodynamic efficiency), which could in turn change the merit order of the efficient electricity operation decision.

The explicit representation of the technological parameters allows for easily adding additional calibration restrictions that require keeping the cost merit order unchanged after the calibration process. Another alternative to improve the mathematical formulation is to use a goal programming approach. This option, adopted in this paper and described in section 3.3, is capable of overcoming all previous described limitations, and additionally, has a completely linear formulation that can be presented as an advantage in comparison with the previously mentioned quadratic approach.

All this said, the objective of this paper is to present a CGE model perfectly suited to address complex electricity issues through the incorporation of several attributes that until now were only present in bottom-up electricity models. The developed CGE presents simultaneously technological and time disaggregation;



macroeconomic aggregates directly obtained from technological micro-foundations; and a goal-programming calibration procedure capable of achieving a TD representation perfectly compatible with BU technological parameters.

### **3 Analytical framework**

#### **3.1 Model Overview**

As previously mentioned, the goal of this paper is to develop a consistent formulation to incorporate load level and technology detail into TD CGE models.

In data terms this requires adding to a SAM not only a column disaggregation, characteristic of the disaggregation of electricity production technologies, but also a row disaggregation necessary to include the load level detail in either the demand profile of economic agents and the available production portfolios of generation technologies.

In terms of equations, additionally to the usual CGE market clearance, zero profit and income balance conditions, this means determining an electricity production structure unique to the electricity sector which includes the load block structure, the presence of geographically independent markets, and the different technology generation assets, and that builds up the macroeconomic aggregates from the available bottom-up information.

The next subsections present the General Equilibrium Model with Electricity Detail product of this work: the GEMED model. The steps necessary to determine the model and, most specially, the process used to achieve the necessary convergence between the CGE TD and the electricity BU formulations are described below.

#### **3.2 The GEMED model**

GEMED is a static, open economy, CGE model applied to the Spanish economy. The functional forms and data requirements necessary to define the model are described below. The equation descriptions and an exhaustive explanation of the GEMED model can be found in Rodrigues and Linares (2012).

Most of the macroeconomic data necessary to define the model were acquired from the Spanish National Institute of Statistics (“Instituto Nacional de Estadística”,

INE) and were consolidated into a SAM for 2005. The 73 sectors partition provided by the national accounts was integrated into seven representative sectors, according to their relationship with the electricity sector: the electricity sector itself, three fuel supplier sectors (Carbon, Oil/Nuclear and Gas) and the three typical electricity demanders besides households (Food and Manufactures, Transport and Services).

The production decision of each sector is represented by a series of nested production functions, except for the electricity sector case. The production factors, Labor and Capital, are combined to produce a value added composite good through the use of a constant elasticity of substitution (CES) production function<sup>4</sup>. The resulting value added composite is combined with the intermediate inputs through a Leontief assumption of fixed proportion of use in order to define the final sector production.

The set of intermediate inputs includes one good for each of the productive sectors, again except for the electricity case. There are two groups of electricity goods to represent the energy and capacity components of the electricity prices. The capacity component includes the Transmission, Distribution and Other activities (TD&O) and is represented by a unique aggregate electricity power product. The energy component produced by the generators (GEN) is represented by  $n$ -dimensional vectors of prices and quantities representing the different load blocks production and demand decisions.

In summary, the CGE model is composed by  $7+lxn$  goods and sectors: three for the fuel sectors, three for the typical demanders, one for the electricity TD&O and  $lxn$  for the electricity GEN products (one for each load block  $n$  at each location  $l$  assumed).

We assume that goods are differentiated according to their sources (Spain and foreign countries). The domestically produced goods are combined with the imported goods in order to produce an equivalent composite good through an Armington aggregation assumption. The total supplied composite good is

---

<sup>4</sup> The elasticities of substitution are taken from the Global Trade Analysis Project data (Hertel & Horridge, 1997) and relevant literature.

confronted with the external and internal demand for goods. Primarily, the amount of goods aimed to exports and the amount heading for the national internal market are divided through the use of a constant elasticity of transformation function (CET). Finally, the remaining internal goods supply faces the national agents' consumption decision represented by the demand of institutions (government and household), the sectors' intermediate input demand and the investment goods demand.

The public sector acts as an owner (of capital and foreign transfers), and as a redistributor of the resources acquired by different transfers and taxes (social contributions, value added taxes, indirect product and production taxes, renewable subsidies, and CO2 allowances distribution). We assume an endogenous public savings level and that the government consumption is a fixed proportion of government expenditure. The provision of public services does not follow these restrictive assumptions. This is aggregated in the services sectors and is modeled assuming factors substitution and the use of intermediate inputs in a similar way to the productive sectors decision described above.

Finally, the model assumes that all savings are spent on investment goods, at fixed investment shares for each sector.

The electricity sector definition requires a more extensive description. As previously said, the electricity commodity is differentiated by type, energy (GEN) and network (TD&O) components. Moreover, the energy component is also differentiated by location<sup>5</sup> and, most particularly, by time of consumption (n load blocks)<sup>6</sup>.

Firstly, it is necessary to define the electricity demand of each agent at each specific time, i.e. the row disaggregation in the SAM. We use different electricity consumption profiles with this intention. The export and import electricity profiles

---

<sup>5</sup> Two independent markets defined by their geographical characteristics are considered in the Spanish case study presented in this paper: the peninsular and the extra peninsular geographical regions.

<sup>6</sup> The different levels of load aggregation used to illustrate the advantages of adopting the load level disaggregation for electricity policy evaluations are described in detail in the section 4.

at the benchmark year are obtained directly from the Spanish electricity system operator database (REE-ESIOS). CNE (“Comisión Nacional de Energía”) data for low voltage consumption (1.0 and 2.0 tariff and market components) were used to define the household demand profile. Lastly, two hypotheses were made to derive the electricity demand profile of the remaining electricity demanders.

The fuel producers (Coal, Oil/Nuclear and Gas) and the manufacturing sector are assumed to be interruptible electricity demanders and as assumed by the “Atlas de la Demanda Eléctrica Española” (Indel, REE, 1997) have a linear, flatter, consumption profile. The remaining agents (Transport and Other Services) have their consumption profile at each load block defined by the residual hourly system profile behavior.

The self-consumption of the generation sector and the energy used by pumping units were used to determine the electricity profile for the GEN load blocks. The transmission losses and the remaining demand of the electricity sector defined the TD&O activity electricity demand profile.

The network access payments of each economic agent (TD&O payments) are obtained by subtracting the expenditure in the energy component of electricity of each agent (load profile times price at the load block) from the SAM total electricity sector expenditure.

Once the demand for electricity at each load level has been defined, we still need to estimate the actual production behavior of the electricity sector TD&O and GEN activities. Figure 1 summarizes the electricity sector productive structure and shows how the network component (TD&O) of the electricity production structure follows a traditional Leontief aggregation structure for combining the production factors and different intermediate inputs. In turn, the energy component (GEN) is disaggregated much further. Each combination of different locations and load block periods is represented by its own share of different electricity production technologies linked, again, by means of a Leontief production function.

Each generation technology has its own Leontief aggregation of production factors and intermediate inputs. The biggest difference here is that these technological parameters are defined to be equivalent to the variable and fixed costs of technical

BU information. The electricity generation technology costs in the CGE description are micro-founded by real world technological characteristics.

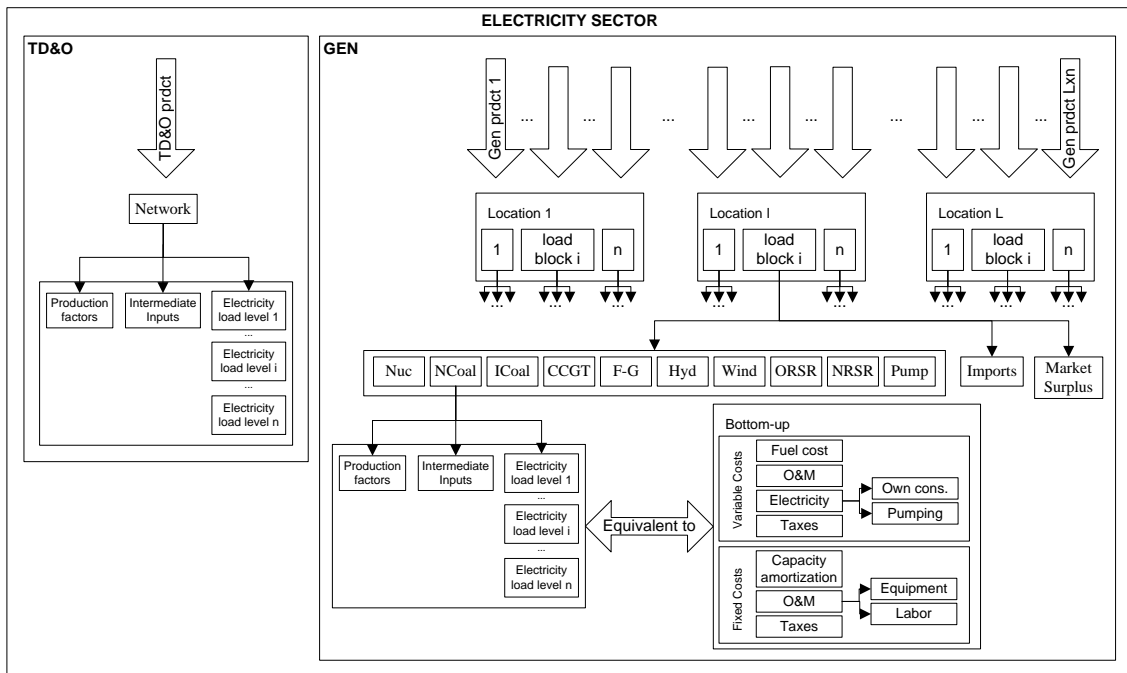

Figure 1. Electricity production structure.

The generation sector fuel demand is obtained from the power plants' thermodynamic efficiency, fuel prices and energy produced. The capital costs depend on installed power, overnight construction costs, construction time, years of amortization, real discount rate and interest rate. Operation and maintenance costs and installed capacity determine the labor costs for each technology. The costs of equipment and other auxiliary materials are derived from fixed and variable maintenance costs for new equipment, installed capacity and energy produced. Social contribution taxes and indirect taxes are a result of labor use and production levels. Finally, as previously mentioned in the demand definition, the use of pumped storage and power plants self-consumption of electricity represent the electricity costs in the productive process.

All non-accounted costs and market imperfection rents are represented by means of an additional term named market surplus in Figure 1.

Regarding data sources, the power plants' thermodynamic efficiency is estimated from the Ministry of Industry, Energy and Tourism (MINETUR) data on fuel use and production by technology. Operation and maintenance fixed and variable costs,

power plants lifetime and construction time, and new capacity overnight costs are taken from Europe Commission reports and US Energy Information Agency. Water availability, pumping efficiency, transmission losses and other Spanish operational data are obtained from REE-ESIOS database.

As we already mentioned, such a diverse and complex description of the electricity sector conveys a series of incompatibilities between BU and TD data. It makes necessary a calibration procedure in order to align the macroeconomic figures for production and demand with the technological parameters. The next section presents such calibration procedure.

It is important to underline also that all equations under the CGE model followed a mixed complementarity formulation. All economic optimization problems are described by their equivalent Lagrangean and Karush-Kuhn-Tucker (KKT) conditions in order to further enable hybrid modeling extensions.

### **3.3 The reconciliation between BU and CGE modeling: The calibration procedure**

Most of the difficulties for building the electricity detailed CGE model lie in the incorporation of bottom-up technological and demand data into the macroeconomic SAM framework. Before showing the calibration process used in this research, we have to identify all assumptions necessary to translate electricity fixed costs and market imperfections into an accountability scheme compatible with the load block disaggregation proposed.

#### **3.3.1 Accounting for fixed costs and market imperfections in the CGE modeling**

Different costs can have different temporal amortization structures. Some costs are directly related to the amount produced (the very definition of variable costs). These costs are easily represented on a load block disaggregated scheme. Other costs however can be problematic to represent in a load block disaggregated scheme: the amortization of fixed costs (including those resulting from excess capacity), the markups in non-competitive markets, or other market imperfections.

Take for example the amortization of the power plants installed capacity. Fixed investment costs are usually paid under an annual amortization schedule. But the

income used to pay such amortization comes from marginal prices, as shown by Pérez-Arriaga and Meseguer (1997) for power systems.

The first problem that we face is how to determine the amount of fixed costs paid by the electricity generating companies in each year. While the total capital payments for the calibration year can be obtained from the company accounts, some ad hoc assumptions need to be made to determine the contribution of each technology to the total amount of investment costs and the proportion of fixed costs paid in each of the years to come.

There is not a “right” or “perfect” way to make these assumptions. However, in the case of the electricity sector, the close relationship between the large amounts of money required for the construction of electricity infrastructure and the strong use of bank loans and financial instruments allows us to consider a well-defined amortization schedule.

We choose to consider the amortization payment of old and new production capacity as an annuity paid during the operation lifetime of the power plant<sup>7</sup>. The total cost to be amortized at the beginning of the power plant lifetime is the overnight cost, which includes interests paid during construction if required.

Even after defining the amortization schedule, the actual money available for paying the electricity fixed costs is income dependable and the company’s income is load block dependable: a second problem emerges.

In marginal settling electricity markets, like the Spanish case, the market price should be equal to the marginal unit bid necessary for supplying total demand. The sector income differs highly between load levels. Therefore, for every non-marginal unit, peak demand periods contribute substantially more to the payment of fixed costs than off-peak periods. Moreover, each technology receives only the amount proportional to its utilization in the load block production level.

---

<sup>7</sup> A bottom-up model usually disregards any impact of previous installed capacity in the costs accountability because their levels do not modify the partial equilibrium future optimal decisions, as they represent sunk costs. However, in a general equilibrium approach the composition of such previous capacity can represent the future solvency of a certain technology; besides it also represents indirect capital effects that should be accounted for the correct evaluation of certain policy assessments.

How much of each load block's income contributes to the payment of the total investment costs and which are the other destinations of the remaining income after paying variable costs?

In a perfectly competitive market and under an exhaustive representation of the activity costs, the sum of the total surplus obtained at each load block after deducting the variable cost payments should correspond exactly to the capital requirements for paying off the corresponding power plant capacity (and any other additional fixed costs). Any divergence from this outcome would result in an arbitrage opportunity in the market, meaning an entry signal to potential competitors and/or the bankruptcy of existing firms.

But neither the exhaustive representation of costs nor a perfect competitive market are the usual cases for the electricity sector structure or for its representation in models. Regarding costs, the complexity and dimensionality issues make impossible to represent the unit commitment detail in an expansion planning model, and vice versa. Moreover, the electricity sector features typically a series of additional market imperfections, market power rents and windfall profits characteristic of each scenario and market structure.

Therefore, the translation of the bottom-up electricity behavior into a TD modeling approach must face at the same time an imperfect competition environment with an undefined proportion of costs paid by load blocks.

Let's start with the second issue: the load block distribution of non-load block specific costs. We assume that all non-variable costs are divided between load blocks according to the proportion of the load block surplus after deducing the specific variable costs pertaining to it. This representation is perfectly compatible with the direct consequences of a perfectly competitive market environment but can be also applied to our imperfectly competitive electricity market.

Now comes the question of how to represent imperfect competition in the TD model. There is not a single way of modeling imperfect competition, but in our case our choice is directed by the need to determine the amount of market imperfection rents acquired at each load block by electricity generators. Therefore, we assume all market imperfections approximated by the surplus between the calibrated



incomes and the bottom-up sources of variable and allocated fixed costs. The total obtained can be easily used to determine a mark-up price for each load block.

This way of representing fixed, variable and market imperfection rents has two consequences. First, all non-explicitly represented costs of the electricity sector are endogenously built-in in the determination of the load block market surplus. Second, there is no motive for the market surplus to be positive in all load blocks; actually, it is expected that lower demand load blocks present smaller market surplus amounts, due to their lower price levels, and that non optimal construction decisions may result in a negative surplus until over the years their amortization levels reduce their influence.

The remaining question to be answered is how to determine all components described in this section (fixed costs distribution, load block surplus, market imperfection rents,...) in a consistent technological and CGE modeling representation.

### **3.3.2 The trick: using a bottom-up model to define a top-down detailed model**

The distribution of the costs not specific of load blocks could be determined by a heuristic or discretionary exogenous assumption. These alternatives however make it difficult to use the same framework for further extensions (such as developing an integrated hybrid BU and CGE model) as they are not necessarily correctly reflected in the BU component.

In order to avoid further incompatibilities, this work makes use of a bottom-up power generation expansion model, based on Linares et al. (2008), to define the costs distribution between load blocks. The electricity expansion and operation model is used in sequence with the calibration process as illustrated in Figure 2.

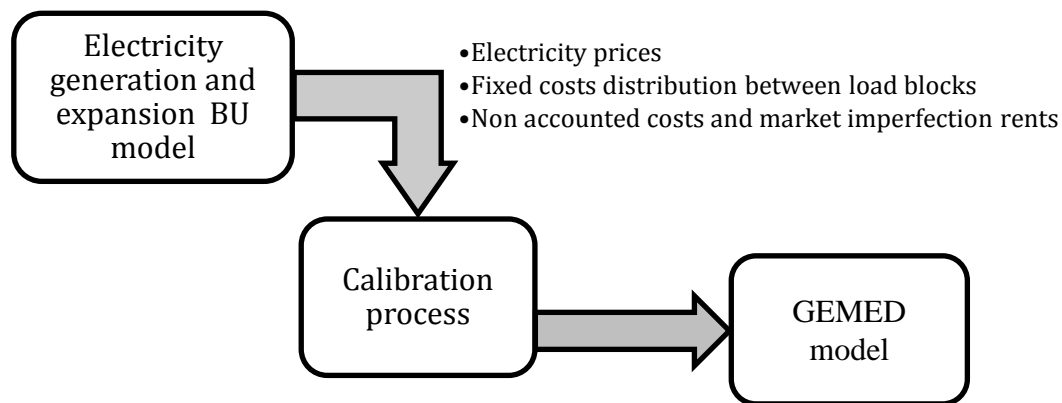

Figure 2. Bottom-up electricity model and calibration procedure linkage.

The marginal operation model aims to represent the electricity market competitive results by choosing the most inexpensive technologies to produce enough electricity to meet demand in a reference year. The variable costs for each load block and the fixed costs for the reference year operation are then identified by the model.

Subsequently, the modeled marginal unit cost is confronted with the observed real world prices in order to define the portion of income and costs not accounted for in the model formulation. Start-up and ramp costs, market imperfection rents and market power use that could be derived from the oligopolistic structure of the market are examples of terms not addressed in the BU model chosen in this work. Even so, one cannot deny the possible presence of these terms in the determination of real world prices, and therefore their consequent presence in the accounting frameworks that define the CGE data.

The resulting modeled prices, added to the adjustment of the costs accounted for in the real world, can be used to obtain the total generation remuneration. The fixed costs are allocated at each load block according to the surplus of this remuneration after deducting the model variable costs.

After excluding the variable and fixed costs, the remaining money represents all economic flows not explicitly described in our BU model. These flows are allocated to remunerate all market imperfections and the non-accounted costs, and they are treated as capital terms in the CGE model.

With all production components described in terms of load block expenditures we can finally describe the calibration process.

### **3.3.3 Calibration formulation**

As previously said, instead of the most common used shares and direct macroeconomic aggregation we calibrate directly the technological parameters; instead of the usual quadratic alternative we opted for a linear calibration procedure; and instead of the technology-only disaggregation we include the time disaggregation at the electricity product (SAM row) and production (SAM column) levels.

The calibration process starts by firstly defining a number of must-follow accountability constraints between the SAM values necessary to maintain the SAM equilibrium. Secondly, determining equations that arithmetically obtain each one of the SAM aggregated values from the technological and demand BU information. Finally, defining a mathematical problem that minimizes the deviations of the benchmarked BU technologic parameters while respecting the macroeconomic expenditure constraints and the SAM equilibrium assumptions.

The structure chosen for approximating the BU values to the aggregated TD expenditure information applied in this work takes the form of a Chebyshev or minimax goal programming approximation (Romero, 1991) and described below:

Min: Maximum\_Deviation 3.3-1

Subject to:

Chebyshev deviation equations:

$$x_i - \bar{q}_i + n_i - p_i = 0 \quad 3.3-2$$

$$\frac{n_i}{k_i} + \frac{p_i}{k_i} \leq \text{Maximum\_Deviation} \quad 3.3-3$$

$$n_i, p_i \geq 0 \quad 3.3-4$$

SAM 'Must follow' accountability equations:

$$X_{\text{row,column}} = \overline{\text{SAM}_{\text{row,column}}} \quad 3.3-5$$

Micro-founded macroeconomic aggregates:

$$X_{\text{row,column}} = f_{\text{row,column}}(x_1, \dots, x_n) \quad 3.3-6$$

Where  $x_i$  are the technological parameter decision variables;  $\bar{q}_i$  are the desirable values of  $x_i$  (i.e. the benchmark technological parameter values);  $n_i$  are the negative deviation variables;  $p_i$  are the positive deviation variables,  $k_i$  are the deviation normalizations associated with the  $i$ th goal,  $X_{\text{row,column}}$  are the SAM macroeconomic aggregates resulting from the calibrated variables,  $\overline{\text{SAM}_{\text{row,column}}}$  are the SAM benchmark data and  $f_{\text{row,column}}(x_1, \dots, x_n)$  are the functions that translate the BU technological parameters into macroeconomic aggregates.

The model considers twelve technological and adjustment parameters necessary to reflect thermodynamic efficiency, overnight construction costs, variable operation and maintenance costs in equipment, fixed operation and maintenance costs in equipment, CO2 equivalent content by fuel, electricity self-consumption, labor and social contribution costs, network losses, imports prices adjustments and exports prices adjustments.

The goal programming formulation adopted is able to overcome the concentration of deviations previously described in section 2 and, if added to the merit order and the must-follow accountability constraints necessary to maintain the SAM

equilibrium, can determine the calibration procedure necessary to match the electricity and the CGE data to completely define the GEMED model.

#### **4 Case study: An evaluation of a demand response program in Spain with the GEMED model**

In order to illustrate the capabilities of the extensions introduced by the GEMED model when dealing with E3 policy evaluations we assess the consequences of a Demand Response (DR) program for household electricity consumers in Spain. This program consists in sending consumers price signals to make them shift or reduce their electricity consumption to better adjust to the system requirements. Basically, the program will result in shifting loads from peak periods, and reducing loads across the board. This may also have indirect effects on electricity prices, and therefore, on electricity demand from other sectors.

The assessment is carried out by comparing results from the BU and CGE models, with and without the DR program.

The BU model used for calibrating the CGE model is applied to simulate the consequences of the load demand reductions and shifts caused by a higher penetration of DR. The model assumes that the households will shift their loads whenever they achieve a minimum savings of 5%. The same policy assessment is carried out in the GEMED model. This model is used to evaluate the indirect impacts not assessed under the BU approach of these load profile changes on other economic agents (sectors and institutions). Both models results are compared to outline the potential of the pure engineering and the extended CGE assessments.

Additionally, different load blocks aggregations are considered in the simulations in order to illustrate the potential of the time disaggregation extension introduced by the GEMED model. Table 1 describes the simulation scenarios assumed by this work.

Table 1. Simulation scenarios.

Scenario name	Number of load blocks	Description
DR_LB_1	1	Typical CGE with one electricity product.
DR_LB_12	12	2 seasons (summer and winter); 2 day types (working and holiday); 3 hour types (off-peak, medium and peak hours).
DR_LB_75	75	5 seasons (winter1, spring, summer, autumn and winter2); 3 day types (working 1: Monday and Friday; working 2: Tuesday, Wednesday and Thursday; and holidays); 5 hour types (super off-peak , off-peak, medium, peak and super-peak)
DR_LB_210	210	5 chronologic seasons (winter1, spring, summer, autumn and winter2); 6 day types (5 working days and 1 holiday) 7 hour types (extreme off-peak, super off-peak, off-peak, medium , peak, super peak, extreme peak)

Source: own elaboration.

The results obtained by the calibration model, necessary to define the GEMED model, are presented in the next section. Then, section 4.2 presents and compares the results obtained by both BU and TD policy assessments models.

#### 4.1 Calibration process

First we compare the results obtained from using two different calibration strategies: the minimax one proposed in the paper, and the quadratic form usually proposed in the literature. The results obtained by the two alternatives are presented in Table 2.

As underlined in the previous section, the main undesirable consequence of the calibration of parameters for the electricity sector operation is the possibility of changing the original cost merit order of the production technologies. Therefore our analysis focused in evaluating the levels of maximum deviated parameters, besides the more usual average error assessment.

Table 2. Parameter with maximum deviation after the calibration process.

Scenario	MinMax		Quadratic	
	Max deviation (%)	Variable with max deviation	Max deviation (%)	Variable with max deviation
DR_LB_1	18.74%	Several variables (O&M variable cost, O&M fixed cost, thermodynamic efficiency, ...)	23.76%	TD&O labor
DR_LB_12	30.70%	Several variables (O&M variable cost, O&M fixed cost, thermodynamic efficiency, ...)	46.91%	TD&O capital
DR_LB_75	38.93%	Several variables (O&M variable cost, O&M fixed cost, thermodynamic efficiency, ...)	59.03%	TD&O capital
DR_LB_210	40.61%	Several variables (O&M variable cost, O&M fixed cost, thermodynamic efficiency, ...)	61.47%	TD&O capital

Source: own elaboration.

The quadratic method under the scenario DR\_LB\_1 is used to compare our paper's formulation with another published calibration method described in Sue Wing's work (2008). However, due to very dissimilar data sets (Spanish vs. United States data) and different use of parameters in the calibration process (technological parameters vs. aggregated shares) we can only say that the method presented by our paper achieved a similar level of magnitude in the calibrated parameters errors when compared to Sue Wing's work. Focusing on the analysis of the maximum deviated parameter, the labor cost faced by the TD&O activity was the parameter which required a larger adjustment to calibrate the data, a 23.76% deviation when compared to the benchmark data, which represents an encouraging outcome if compared with the 43.2% obtained in the Sue Wing model for the maximum calibrated error (of steam turbine generation expenditures). Again, it is important to emphasize that this result does not prove that our calibration procedure is any better than Sue Wing's proposal, due to different data sets and calibrated parameters.

Nonetheless, stronger conclusions can be drawn when comparing the quadratic formulation and the minimax alternative for the same dataset. Table 2 results show that the minimax model consistently bests the quadratic alternative in terms

of maximum errors on the calibrated parameters. Moreover, it requires less computer memory resources and achieves faster solving times<sup>8</sup>.

We therefore argue that there are clear advantages in using the calibration procedure described in this paper. The next step in this case study is to compare a pure BU vs. a pure TD electricity technology detailed CGE formulation, vs. the electricity load level disaggregated and electricity technology detailed TD GEMED model, for the same assessment of the Demand Response program.

## **4.2 Assessment of the Demand Response program**

The DR program promotes savings from conservation and load shifts in the order of 2% to 3% of the electricity operation costs in the reference year<sup>9</sup> (see Table 3). Its global effect in the economy corresponds to a demand shock, which contracts the economic activity by the corresponding electricity demand contraction level, and a total income retraction because of the electricity demand shifts from expensive hours to cheaper load blocks. The more load blocks are considered in the model simulation, the closer to the real operation of the electricity sector is the simulation, and the larger are the demand shock, the income retraction, and the power system benefits of the DR program.

---

<sup>8</sup> Information about the execution time and memory requirements took for each model is available upon author request.

<sup>9</sup> The results presented in this section for the BU and the TD models aggregates the two different Spanish regions considered in the original model for the sake of simplicity and brevity of explanations.



Table 3. Demand response policy BU results for the year 2005.

Scenario	BAU	DR	Potential DR savings		
	Total cost (10 <sup>6</sup> €)	Total cost (10 <sup>6</sup> €) (%)	Total savings (10 <sup>6</sup> €) (%) <sup>a</sup>	Conservation (10 <sup>6</sup> €) <sup>c</sup> (%) <sup>a</sup>	Displacement (10 <sup>6</sup> €) <sup>c</sup> (%) <sup>a</sup>
<b>DR_LB_1</b>	10,367	10,162 (-1.98%)	205 (2.02%)	205 (2.02%)	0 (0.00%)
<b>DR_LB_12</b>	10,473	10,186 (-2.74%)	302 (2.96%)	248 (2.43%)	54 (0.53%)
<b>DR_LB_75</b>	10,503	10,177 (-3.10%)	356 (3.50%)	268 (2.63%)	89 (0.87%)
<b>DR_LB_210</b>	10,503	10,156 (-3.30%)	337 (3.32%)	283 (2.78%)	54 (0.53%)

Source: own elaboration.

It should be reminded here that our goal is not to provide an exhaustive assessment of the DR program (we do not consider for example the impact on network congestions or investments), but to show the advantages of using our GEMED model for this evaluation when confronted with the BU and the non-time disaggregated CGE alternatives. Therefore, we only summarize the main consequences of this policy and use their results to evaluate the different models addressed in this paper<sup>10</sup>.

As mentioned before, the GEMED model is able to account for indirect effects not considered by BU models. Namely, the impact of lower electricity prices on the electricity demand of other sectors, which in turn results in a higher overall electricity demand. Similar effects could also happen for capital production factor prices (as electricity is a highly intensive demander of capital), and to a lower degree for labor prices. The agents are also susceptible to more effects due to the presence of an income effect, whenever the savings in electricity costs are translated to the electricity prices, and an endogenous reduction of the DR attractiveness, as the lower prices reduces the potential savings of adopting DR measures.

The effects described above act in the opposite direction of the reduction in the BU electricity demand promoted by DR program. The results of the program are therefore dampened in a general equilibrium context. A partial equilibrium model

---

<sup>10</sup> The work of Rodrigues et al. (2011) describes in more detail the DR general equilibrium assessment under a simple CGE model without load block disaggregation. The same policy assessment exercise could be applied as a future work to a CGE model with load block disaggregation as the GEMED model.

does not take into account such consequences, thus overestimating the consequences of the DR program.

As expected, the results of the general equilibrium model reflect exactly this behavior. The percentage of electricity demand reduction in the BU model is larger than in the GEMED model in any of the load block disaggregations assessed (see Table 4 and Table 5 respectively) <sup>11</sup>.

Table 4. BU electricity operation results for prices and quantities.

	BAU	BU DR counterfactual simulation				Difference
Scenario	Total income (10 <sup>6</sup> €)	Total income (10 <sup>6</sup> €) (%) <sup>a</sup>	Price (€/MWh) <sup>b</sup> (%) <sup>a</sup>	Quantity (GW) <sup>b</sup> (%) <sup>a</sup>	Emissions (%) <sup>d</sup>	Final consumer savings (10 <sup>6</sup> €)
<b>DR_LB_1</b>	13,138	12,903 (-1.79%)	52.84 (0.00%)	244,152 (-1,79%)	-1.80%CO <sub>2</sub> e -0.52%Acid e -0.38%PM10	235
<b>DR_LB_12</b>	15,867	14,190 (-10.57%)	58.19 (-8.83%)	243,865 (-1.91%)	-2.42%CO <sub>2</sub> e -0.82%Acid e -0.63%PM10	1,677
<b>DR_LB_75</b>	16,490	14,433 (-12.48%)	59.25 (-10.65%)	243,586 (-2,04%)	-2.72%CO <sub>2</sub> e -0.95%Acid e -0.75%PM10	2,057
<b>DR_LB_210</b>	16,605	14,224 (-14.34%)	58,49 (-12,41%)	243,194 (-2,20%)	-2.90%CO <sub>2</sub> e -1.01%Acid e -0.79%PM10	2,381

Source: own elaboration.

- Prices, quantities (Quant.), emissions (Emiss.) and costs variations are accounted in relation to the business as usual benchmark values (BAU).
- Yearly price weighted by electricity quantity transacted at each load block. Total electricity demand quantity in the year.
- Emissions variations are measured in respect to the benchmark business as usual values and are represented in terms of CO<sub>2</sub>e content and acid equivalence (SO<sub>x</sub> = 0,031 acid eq/g; NO<sub>x</sub>=0,022 acid eq/g; NH<sub>3</sub> = 0,059 acid eq/g). For the GEMED model we consider constant emission factors applied to the final produced quantities of each productive sector commodity.

---

<sup>11</sup> The absolute values of the TD GEMED and the BU models quantities and prices are not directly comparable because the models depart from distinct parameter values. The BU parameters are based in the original technological information meanwhile the TD parameters are based on the calibrated parameters. By this motive, from now on most of the evaluation presented in the paper focus on analyzing percentage variation values between BAU and case study results.

Table 5. GEMED results for generation sector prices and quantities.

	BAU	GEMED DR counterfactual simulation				Difference
Scenario	Total income (10 <sup>6</sup> €)	Total income (10 <sup>6</sup> €) (%) <sup>a</sup>	Price (p.u.) (%) <sup>c</sup>	Quantity (p.u.) (%) <sup>c</sup>	Emissions (%)	Final consumer savings (10 <sup>6</sup> €)
<b>DR_LB_1</b>	13,060	12,847 (-1.63%)	52.86 (0.01%)	243,068 (-1.64%)	-1.64% CO <sub>2</sub> e -1.64% Acid e	213
<b>DR_LB_12</b>	15,141	14,859 (-1.86%)	61.23 (-0.06%)	242,684 (-1.80%)	-1.80% CO <sub>2</sub> e -1.80% Acid e	282
<b>DR_LB_75</b>	15,538	15,226 (-2.01%)	62.81 (-0.07%)	242,399 (-1.94%)	-1.94% CO <sub>2</sub> e -1.94% Acid e	312
<b>DR_LB_210</b>	15,613	15,238 (-2.40%)	63.03 (-0.21%)	241,762 (-2.20%)	-2.20% CO <sub>2</sub> e -2.20% Acid e	375

Source: own elaboration. p.u. = per unit.

d. Prices and quantities were adjusted at the calibration stage to reflect the initial sector demand (GW) and prices (€/MWh) conditions.

Around 373 MWh of the BU decrease in electricity demand (about 8.38% of the original reduction promoted by the program) are rebounded when the general equilibrium indirect effects are considered in the DR\_LB\_1 scenario. As more load blocks are included, the quantity rebound effects decreases, to 5.76%, 4.90% and ~0% under 12, 75, and 210 load blocks respectively. This result is driven by the fact that as more load blocks are considered, the higher is the demand-response load shifting and the flatter the resulting electricity demand profile. Under a lower average price and less extreme peak demand and prices, the other agents in the economy have fewer incentives to change their behavior, reducing the influence of the indirect effects into the policy results, and consequently, reducing the importance of rebound effects.

On the other hand, GEMED prices are higher and vary much less (-0.21% to 0.01%) compared to the partial equilibrium results (-12.41% to 0.00%). This smaller variation is mostly due the fact that the general equilibrium model continues to make use of Leontief production functions to reflect the combinations of generation technologies (nuclear, CCGT, Wind, etc.). This production structure, unlike the BU costs minimization problem, is unable to completely drop the use of more expensive technologies even when the peak demand reduction is very high. Additionally, the initial prices at the business as usual benchmark are higher under the GEMED model because they include adjusted parameters necessary to reflect additional costs not included in the original BU model formulation.

In both models the DR potential for consumer savings increases as the number of load blocks evaluated increases. This is reasonable because the more load blocks represented, the better the representation of electricity operation under lower and upper bound demand, the better the evaluation of more extreme electricity price levels, and consequently, the higher the incentives to apply DR measures. The difference between the models' total economic savings are largely explained by the already mentioned difference in prices, mostly derived from the consequences of the Leontief approach on the general equilibrium model.

Two much more important facts can be drawn from the results to justify the use of load blocks disaggregation in a CGE evaluation of an electricity policy. Under a single load block assumption (DR\_LB\_1 scenario) the GEMED model behaves as the usual technology-only disaggregated CGE. This model form is incapable of evaluating endogenously the load shifts effects necessary for a correct evaluation of DR programs benefits, the introduction of electric cars, the consequences of smart metering or smart grid flexibility, etc. This fact is clear when we look at the lack of savings due to load shifts under the DR\_LB\_1 scenario described in Table 3.

More importantly, the direction of the consequences of the DR program in prices is not correctly addressed if the analysis does not include load blocks disaggregation. Theoretically the DR response policy should clearly reduce prices; however, the 1.64% electricity demand drop promoted by the DR program in scenario DR\_LB\_1 is followed by an increase of 0.01% in electricity prices in the CGE model formulation with only one electricity commodity, i.e. not differentiated in time. If we consider the load block disaggregation this picture changes. Even with few load blocks (DR\_LB\_12 scenario) the CGE results follows the intuitive results of the BU model by reducing average electricity prices (-0.06%) together with the reduction in demand (-1.80%). Actually, the law of demand still holds under the CGE with load block disaggregation. What happens is that the higher price load blocks suffer a higher contraction in demand, as would be expected in the DR program, and their effect in average prices are accentuated. This is much more evident if we compare directly the results of two scenarios: DR\_LB\_1 scenario (Table 6) and DR\_LB\_12 scenario (Table 7).

Table 6. Typical CGE (GEMED DR\_LB\_1 scenario) simulation results.

		Business as usual benchmark		GEMED DR counterfactual simulation		
		Price (p.u.) <sup>e</sup>	Quantity (p.u.) <sup>e</sup>	Price (p.u.) (%) <sup>e</sup>	Quantity (p.u.) (%) <sup>e</sup>	Emissions (%)
<b>Products</b>	<b>Electricity GEN</b>	52.85	247	52,86 (0.01%)	243 (-1.64%)	-1.64% CO <sub>2</sub> e -1.64% Acid e
	<b>Electricity TD&amp;O</b>	1	15,310	~1 (-0.03%)	15,311 (0.004%)	-
	<b>Manufacturing</b>	1	778,107	~1 (-0.03%)	778,063 (-0.01%)	0.01% CO <sub>2</sub> e 0.01% Acid e
	<b>Coal</b>	1	2,413	~1 (-0.01%)	2,386 (-1.09%)	-1.07% CO <sub>2</sub> e -1.07% Acid e
	<b>Oil/Nuclear</b>	1	32,156	~1 (-0.03%)	32,157 (0.002%)	0.04% CO <sub>2</sub> e 0.04% Acid e
	<b>Gas</b>	1	7,641	~1 (-0.03%)	7,595 (-0.61%)	-0.61% CO <sub>2</sub> e -0.61% Acid e
	<b>Transport</b>	1	75,496	~1 (-0.03%)	75,508 (0.01%)	0.03% CO <sub>2</sub> e 0.03% Acid e
	<b>Other Services</b>	1	842,818	~1 (-0.03%)	842,822 (0.0004%)	0.01% CO <sub>2</sub> e 0.01% Acid e
<b>Production factors</b>	<b>Labor</b>	1	334,314	~1 (-0.01%)	334,314 (0.00%)	-
	<b>Capital</b>	1	377,149	~1 (-0.06%)	377,148 (0.00027%)	-

Source: own elaboration. p.u. = per unit.

- e. Prices and quantities in the table do not necessarily reflect real world units because the CGE model is a relative price model by definition. Only the energy component of electricity prices and quantities were adjusted at the calibration stage to reflect the initial sector demand (10<sup>3</sup> GW) and prices (€/MWh) conditions.

Table 7. GEMED DR\_LB\_12 scenario 2005 results.

				Business as usual benchmark		GEMED DR counterfactual simulation			
				Price (p.u.) <sup>e</sup>	Quantity (p.u.) <sup>e</sup>	Price (p.u.) (%) <sup>e</sup>	Quantity (p.u.) (%) <sup>e</sup>	Emissions (%)	
<b>Products</b>	<b>Generation (Electricity energy component GEN)</b>	<b>Winter</b>	<b>Holiday</b>	<b>Off-peak</b>	50.54	6	50,67 (0.26%)	6 (-2.48%)	-2.48% CO <sub>2</sub> e -2.48% Acid e
				<b>Med.</b>	50.62	22	50.70 (0.15%)	22 (-2.11%)	-2.11% CO <sub>2</sub> e -2.11% Acid e
				<b>Peak</b>	50.71	9	50.82 (0.23%)	9 (-3.45%)	-3.45% CO <sub>2</sub> e -3.45% Acid e
			<b>Work day</b>	<b>Off-peak</b>	50.61	13	50,54 (-0.14%)	14 (1.19%)	1.19% CO <sub>2</sub> e 1.19% Acid e
				<b>Med.</b>	54.27	55	54,35 (0.15%)	53 (-2.25%)	-2.25% CO <sub>2</sub> e -2.25% Acid e
				<b>Peak</b>	106.62	22	107,23 (0.57%)	21 (-3.56%)	-3.56% CO <sub>2</sub> e -3.56% Acid e
		<b>Summer</b>	<b>Holiday</b>	<b>Off-peak</b>	50.62	5	50,24 (-0.74%)	5 (6.06%)	6.06% CO <sub>2</sub> e 6.06% Acid e
				<b>Med.</b>	50.64	18	50,77 (0.25%)	18 (-2.90%)	-2.90% CO <sub>2</sub> e -2.90% Acid e
				<b>Peak</b>	50.67	7	50,79 (0.23%)	7 (-3.42%)	-3.42% CO <sub>2</sub> e -3.42% Acid e
			<b>Work day</b>	<b>Off-peak</b>	50.65	14	50,53 (-0.24%)	14 (2.17%)	2.17% CO <sub>2</sub> e 2.17% Acid e
	<b>Med.</b>			50.67	54	50,70 (0.07%)	53 (-1.38%)	-1.38% CO <sub>2</sub> e -1.38% Acid e	
	<b>Peak</b>			106.66	21	107,27 (0.57%)	21 (-3.45%)	-3.45% CO <sub>2</sub> e -3.45% Acid e	
	<b>Weighted Total</b>		61.27	247	61,23 (-0.06%)	243 (-1.80%)	-1.80% CO <sub>2</sub> e -1.80% Acid e		
	<b>Electricity TD&amp;O</b>		1	12,937	~1 (-0.03%)	12,938 (0.004)	-		
	<b>Manufacturing</b>		1	778,107	~1 (-0.04%)	778,043 (-0.01%)	0.02% CO <sub>2</sub> e 0.02% Acid e		
	<b>Coal</b>		1	2,413	~1 (-0.01%)	2,383 (-1.24%)	-1.21% CO <sub>2</sub> e -1.21% Acid e		
	<b>Oil/Nuclear</b>		1	32,156	~1 (-0.04%)	32,153 (-0.01%)	0.04% CO <sub>2</sub> e 0.04% Acid e		
	<b>Gas</b>		1	7,641	~1 (-0.05%)	7,573 (-0.89%)	-0.89% CO <sub>2</sub> e -0.89% Acid e		
	<b>Transport</b>		1	75,496	~1 (-0.05%)	75,512 (0.02%)	0.05% CO <sub>2</sub> e 0.05% Acid e		
	<b>Other Services</b>		1	842,818	~1 (-0.04%)	842,815 (-0.0004%)	0.01% CO <sub>2</sub> e 0.01% Acid e		
<b>Production factors</b>	<b>Labor</b>		1	334,314	~1 (-0.01%)	334,314 (0.00%)	-		
	<b>Capital</b>		1	375,824	~1 (-0.08%)	375,821 (-0.001%)	-		

Source: own elaboration. p.u. = per unit.

As can be seen in Table 7 the introduction of time differentiation for the electricity commodity allows representing much more accurately the price differences between peak and off-peak periods. The prices of GEMED DR\_LB\_12 scenario vary from 50.54 €/MWh to 106.62 €/MWh, which allows a much better representation in the model of the incentives for emission reductions or other sectors peak load reductions. As already mentioned, the weighted price under the disaggregated load

block scenario (61.23 €/MWh) drops in relation to the BAU value (61.27 €/MWh) because of the introduction of the different load blocks. This is not possible under the single load block assumption.

These facts corroborate the point that average prices, like the ones used in the traditional CGE modeling approach, are insufficient to represent correctly the behavior of marginal markets like those in the electricity sector. A multiple electricity commodity representation with load block disaggregation like the one included in the GEMED model is able to represent much more accurately the electricity market behavior even under a pure TD approach.

Besides from the load block disaggregation approach validation, the GEMED model also provides important results related to the consequences to other sectors and institutions of the program assessed. Comparing the one commodity and twelve load blocks scenarios, it is evident that the additional time disaggregation maintains the indirect effects of a typical general equilibrium model, but, more importantly, at the same time reproduces much more accurately the BU production decision dynamics and its major influences on total production and fuel suppliers quantities.

The quantities that vary the most from the one block to the twelve blocks scenarios are electricity (1.80%-1.64%=0.16% of difference between the BAU and the DR program scenarios, which corresponds to an additional 10% reduction for the case with more load blocks evaluated), coal (0.15% difference and an additional 14% reduction for DR\_LB\_12 coal demand) and gas quantities (0,28% difference and an additional 46% reduction for DR\_LB\_12 gas demand). These are exactly the sectors that would suffer the most from an increase in DR in partial equilibrium analysis: the electricity sector because of the drop in its demand and the peak generation fuel suppliers because of their drop in demand as consequence of the electricity load shift.

The original single commodity CGE disregards most of these effects, as they are intrinsically related with the BU marginal behavior of the electricity market, undermining the program evaluation results.

All other sectors and production factors not directly related with the BU DR program maintained percentages of variation close to the original single block model results (variations range from -0.012% to 0.01% between the BAU and policy scenarios).

The results presented in this section prove therefore that the introduction of load blocks in the CGE model improved substantially the representation of the electricity sector and the electricity fuel supplier behavior, even when compared with an already detailed electricity technology CGE. As more load blocks are considered, more substantial are the gains of information conveyed by the model, and more substantial are the improvements of the GEMED time disaggregated model when compared with pure CGE or technology extended alternatives.

## **5 Conclusion**

The increasing electrification of energy systems across the world, and the growing role of policies that change the way in which electricity is consumed, such as demand response programs or the introduction of electric vehicles, make it more necessary than ever a correct representation of the electricity sector in CGE models, so that, while retaining the assessment of indirect effects characteristic of CGE models, we may be able to account correctly for the effect of load shifts and technological changes.

This paper has presented the first attempt to our knowledge at building temporal disaggregation into a CGE model, while keeping technological detail. This contribution is coupled with some methodological improvements over existing technology-rich CGE models, in particular a minimax calibration procedure made possible by the micro-founded representation of the electricity macroeconomic accounts, and which presents clear advantages in terms of calibration results, easiness in adding additional detail to the constraints, memory requirements and solving times when compared to the calibration methods used in previous research.

In addition, we have shown the feasibility of applying our GEMED model to a real-world problem, the assessment of a Demand Response program in Spain. The case study takes into account the actual Spanish electricity facilities and technology availability, the electricity sector operation and future investments decision, and the national accounting data of the Spanish economy. We have also included two



distinct electricity markets with different conditions, the peninsular and the extra-peninsular one. The DR policy assessment was applied to different levels of load block disaggregation in order to show the advantages of such an extension in energy policy evaluations carried out with CGE models.

The addition of load block disaggregation allowed the CGE model to assess endogenously the effects of load shifts, impossible to represent under a single load block assumption. Moreover, the CGE with electricity load level detail described the electricity sector decision in a much more similar way than the BU partial equilibrium model behavior. The resulting TD model mimics the rich description of the electricity sector production decisions present in the BU electricity models without overlooking the indirect effects and inter-sectorial and institutional consequences of the energy policies.

This improved representation of electricity prices enriches the evaluation of indirect and rebound effects by the CGE modeling approach. The direct consequence of such an extension is a better representation of the policy consequences on other sectors.

Nevertheless, the results obtained by this paper are still susceptible to improvements. The GEMED electricity sector production structure still uses the Leontief formulation, and hence includes some inherent limitations. A partial equilibrium model allows that marginal technologies may be retired if not competitive. However, the Leontief formulation assumes a fixed proportion of technologies for each load block, which limits the retirement of more expensive technologies. Similarly, the inclusion of backstop technologies, very relevant in long run policy assessments, is also limited under this production function structure. Therefore, a clear field of future research is the change of the production function formulation, which would require moving to a completely integrated mixed complementarity hard-link hybrid TD-BU model. Research is currently under way to determine calibration procedures, equation formulations and decomposition techniques for such a model, and in particular, to using it in a real-world setting.

This hybrid approach would also allow for a much more detailed representation of the BU model, in particular for the inclusion of start-up costs, intermittent sources,

which are also becoming more and more relevant in electricity systems with the large-scale introduction of renewables.

## **Acknowledgements**

This paper is based on research partly funded by the CENIT-GAD project. We also acknowledge partial support from the Spanish Ministry of Economy and Competitiveness (ECO2009-14586-C02-01). All views expressed here, as well as any errors, are the sole responsibility of the authors.

## References

- Beckman, J., Hertel, T., & Tyner, W. (2011). Validating energy-oriented CGE models. *Energy Economics*, 33(5), 799-806. Elsevier B.V. doi:10.1016/j.eneco.2011.01.005
- Burniaux, J., & Nicoletti, G. (1992). Green: A Global Model for Quantifying the Costs of Policies to Curb CO<sub>2</sub> Emissions. *OECD Economic*. Retrieved from <http://www.sigmaweb.org/dataoecd/44/20/35044127.pdf>
- Burniaux, J.-M., & Truong, T. P. (2002). GTAP-E: an energy-environmental version of the GTAP model. *GTAP Technical Papers No. 16*. Retrieved from [http://docs.lib.purdue.edu/cgi/viewcontent.cgi?article=1017&context=gtap\\_tp](http://docs.lib.purdue.edu/cgi/viewcontent.cgi?article=1017&context=gtap_tp)
- Bye, B., & Jacobsen, K. (2011). Restricted carbon emissions and directed R & D support ; an applied general equilibrium analysis. *Energy Economics*, 33(3), 543-555. Elsevier B.V. doi:10.1016/j.eneco.2010.12.007
- Böhringer, C., & Rutherford, T. F. (2008). Combining bottom-up and top-down. *Energy Economics*, 30(2), 574–596. Elsevier. doi:10.1016/j.eneco.2007.03.004
- Fæhn, T., Gómez-Plana, A. G., & Kverndokk, S. (2009). Can a carbon permit system reduce Spanish unemployment? *Energy Economics*, 31(4), 595-604. Elsevier B.V. doi:10.1016/j.eneco.2009.01.003
- Ghersi, F., & Hourcade, J.-C. (2006). Macroeconomic consistency issues in E3 modeling: the continued fable of the elephant and the rabbit. *The Energy Journal*, 39-61.
- Hertel, T., & Horridge, M. (1997). GTAP Book-Essential Programs. *Center for Global Trade Analysis, Purdue*.
- Hogan, W., & Manne, A. (1977). *Energy Economy Interactions: The Fable of the Elephant and the Rabbit?* (C. J. Hitch, Ed.). Modeling Energy-Economy Interactions: Five Approaches: 247-277. Resources for the Future. Washington, DC.
- Lanz, B., & Rausch, S. (2011). Abatement, (MIT Joint Program on the Science and Policy of Global Change. Report no. 194.).
- Linares, P., Javiersantos, F., Ventosa, M., & Lapiedra, L. (2008). Incorporating oligopoly, CO<sub>2</sub> emissions trading and green certificates into a power generation expansion model. *Automatica*, 44(6), 1608-1620. doi:10.1016/j.automatica.2008.03.006
- Löfgren, H., Harris, R. L., & Robinson, S. (2002). A standard computable general equilibrium (CGE) model in GAMS. *TMD discussion papers 75, International Food Policy Research Institute (IFPRI)*. Retrieved from <http://books.google.com/books?hl=en&lr=&id=aG3s1dNv110C&>

oi=fnd&pg=PR5&dq=A+Standard+Computable+General+Equilibrium+(+CGE+)+Model+in+GAMS&ots=t\_f2fg1SKc&sig=IBnAkVxqVmYnw\_xqsvSBxf12QH4

- Löschel, A., & Otto, V. M. (2009). Technological uncertainty and cost effectiveness of CO<sub>2</sub> emission reduction. *Energy Economics*, 31, S4-S17. Elsevier B.V. doi:10.1016/j.eneco.2008.11.008
- McFarland, J. R., & Herzog, H. J. (2006). Incorporating carbon capture and storage technologies in integrated assessment models. *Energy Economics*, 1-24. Retrieved from <http://www.sciencedirect.com/science/article/pii/S0140988306000594>
- McFarland, J., & Reilly, J. (2004). Representing energy technologies in top-down economic models using bottom-up information. *Energy Economics*, 26(4), 685-707. doi:10.1016/j.eneco.2004.04.026
- Paltsev, S., Reilly, J. M., Jacoby, H. D., Eckaus, R. S., Mcfarland, J., Sarofim, M., Asadoorian, M., et al. (2005). *MIT Joint Program on the Science and Policy of Global Change ( EPPA ) Model : Version 4. Policy Analysis*. Cambridge, USA: MIT, Joint Program on the Science and Policy of Global Change, Report No. 125.
- Pérez-Arriaga, I. J., & Meseguer, C. (1997). Wholesale marginal prices in competitive generation markets. *IEEE Transactions on Power Systems*, 12(2).
- Rausch, S., Metcalf, G. E., & Reilly, J. M. (2011). Distributional impacts of carbon pricing: A general equilibrium approach with micro-data for households. *Energy Economics*, 33, S20-S33. Elsevier B.V. doi:10.1016/j.eneco.2011.07.023
- Robinson, S., Yu, A., Lewis, J. D., & Devarajan, S. (1999). From stylized to applied models: Building multisector CGE models for policy analysis '. *Journal of Economics and Finance*, 10, 5-38.
- Rodrigues, R., & Linares, P. (2012). *Technical Report: GEMED – General Equilibrium Model with Electricity Detail*. Madrid. Spain. Retrieved from [http://www.iit.upcomillas.es/rdias/Static\\_GEMED.html](http://www.iit.upcomillas.es/rdias/Static_GEMED.html)
- Rodrigues, R., Linares, P., & Gómez-Plana, A. G. (2011). A CGE assessment of the impacts on electricity production and CO<sub>2</sub> emissions of a residential demand response program in Spain. *Estudios de Economía Aplicada*, 29(2), 665-(36 pages).
- Romero, C. (1991). *Handbook of critical issues on goal programming*. Pergamon Press, Oxford.
- Rutherford, T., & Montgomery, W. D. (1997). *CETM: a dynamic general equilibrium model of global energy markets, carbon dioxide emissions and international trade*. Retrieved from <http://scholar.google.com/scholar?hl=en&btnG=Search&q=intitle:CETM:+A+D>

ynamic+General+Equilibrium+Model+of+Global+Energy+Markets,+Carbon+Dioxide+Emissions+and+International+Trade#0

Sue Wing, I. (2008). The synthesis of bottom-up and top-down approaches to climate policy modeling: Electric power technology detail in a social accounting framework. *Energy Economics*, 30(2), 547–573. Elsevier.  
doi:10.1016/j.eneco.2006.06.004

Turner, K., & Hanley, N. (2011). Energy efficiency, rebound effects and the environmental Kuznets Curve. *Energy Economics*, 33(5), 709-720. Elsevier B.V. doi:10.1016/j.eneco.2010.12.002